



WATER MASTER PLAN

FOR

THE KINNELOA IRRIGATION DISTRICT

Adopted by the Board of Directors on June 20, 2000

Revision 1 dated June 20, 2005
Adopted September 20, 2005

Revision 2 dated October 21, 2007
Adopted January 15, 2008

Revision 3 dated January 2, 2014
Adopted May 20, 2014

Revision 4 dated June 20, 2018
Adopted July 31, 2018

Melvin L. Matthews
General Manager

Kinneloa Irrigation District
1999 Kinclair Drive
Pasadena, CA 91107-1017
(626) 797-6295

WATER MASTER PLAN EXECUTIVE SUMMARY

The Water Master Plan for the Kinneloa Irrigation District (KID) provides a description of the KID's domestic water distribution system. It describes present, historical, and future water demands and potential future changes in the source of water supply. The Master Plan identifies and prioritizes necessary improvements and sets out cost estimates for implementing the improvements.

Since its formation in 1953, the KID made minor renovations or upgrades to its system, based on a policy only to repair or replace facilities and pipelines as needed. However, by the mid-1990s many factors convinced the Board and many residents that significant upgrades to the system were needed.

Originally in 1953, the KID's minimum fire flow standard was 750 gallons per minute (gpm) for 2 hours. This means that a fire truck could pump 750 gpm for up to 2 hours for a fire and all other homes in the same pressure zone would have enough residual pressure for basic domestic needs. Then in 1973 the Improvement District No. 1 (formerly Mira Loma Mutual Water Company) was designed for an average fire flow of 1,000 gpm with 20 pounds per square inch (psi) residual. However, average means not every fire hydrant would meet this current standard. Currently, the County of Los Angeles Fire Department has a minimum standard of 1,250 gpm to be pumped for 2 hours. Today, in 2018, approximately 20% of the current system does not meet the new standard for fire flow and fire hydrant location. The firestorm of October 1993 exposed weaknesses in the KID's pipeline delivery capacities. The Fire Preparedness Policy (FPP) was developed in February 1997 and revised in April 2005 and January 2018. The intent of the FPP was to set goals to be achieved to prepare for future multiple structure fires within the KID community. As a result, the KID Fire Preparedness Policy now requires that all new facilities, including pipe, be sized to support a fire flow of 1,250 gpm with 20 psi minimum residual for 4 hours. The FPP is included as Exhibit III in the Appendix.

The information and data used in the Water Master Plan were developed from many sources:

- Discussions with the KID staff.
- A review of KID files dating back to 1953 was used for a baseline to build the initial data.
- Hydraulic studies completed for the Kinneloa Ridge Development and the Doyne Road Development contributed important information to the plan.
- The average day and maximum day demands were developed during the 1990-1991 droughts.

In April of 1996, ASL Consulting Engineers conducted a study of the KID to identify water main and reservoir improvements required to increase water system capabilities to deliver domestic demands plus 1,250 gpm fire flows. As a part of this plan ASL Consulting Engineers prepared cost estimates in April 1996, with updates in February of 2000. The General Manager reviewed these estimates and adjusted for inflation and other factors to update the plan for 2005, 2007, 2014 and again for this update in 2018.

After significant discussions and review of the original plan the Board determined that modification of the existing KID reservoirs was too expensive and would involve costly environmental studies. The Board determined that pump station improvements would better serve the District by concentrating on providing booster station flow capacities to achieve the desired fire flows of 1250 gpm. Original cost estimates for

KID funded improvements to reservoirs are in Exhibit I of the Appendix but are not included in the Water Master Plan projects or current cost estimates. However, should outside sources of funding become available consideration of these projects will be re-evaluated since increased reservoir storage capability is still an important objective of the District to prepare for all types of emergencies and to provide operational flexibility.

In addition to implementing pump station improvements the preparation of the Water Master Plan includes the following goals:

- All pipes that develop chronic leaks should be replaced to achieve overall lower operational cost and minimize emergency shut-downs.
- Pipelines, which have become inaccessible due to development or are crossing private property should be relocated.
- Pipelines should be upsized where required to meet the Fire Preparedness Policy goals.
- Preferred installation for booster pumps should be high efficiency vertical turbine units.
- Water tunnels and transmission lines should be maintained as a supplemental source of water with gravity flow to reservoirs.
- The KID should continue to fund planned maintenance on all facilities.

The total estimated costs of all necessary improvements as identified in the Water Master Plan adopted in 2000 were:

1. Pipeline Improvements	\$1,192,600
2. Pump Station Improvements	\$ 108,200
3. Tunnels	\$ 421,900
4. Other Improvements	<u>\$ 395,500</u>
Total	\$2,118,200

The total estimated costs as revised and updated by the General Manager in 2005 were:

1. Pipeline Improvements	\$1,899,600
2. Pump Station Improvements	\$ 3,600
3. Tunnels	\$ 321,000
4. Other Improvements	\$ 271,000
5. Planned Maintenance	<u>\$ 687,400</u>
Total	\$3,182,600

The difference between the 2000 costs and 2005 costs was an increase of \$1,064,400. The net increase was attributed to the following factors:

- Inclusion of planned maintenance items in the amount of \$687,400 that are expected over the next ten years.
- The estimated cost of remaining projects after removing completed projects and adding new projects identified since the master plan was adopted.
- Adjustment of previous costs to reflect inflationary and other factors in current project costs.
- Exclusion of projects paid by developers.

The following projects were completed between the 2005 and 2007 revisions:

- East Tank was refurbished.
- K-3 Well pump and motor were rebuilt.

- One of the Holly booster pumps was rebuilt.
- Safety upgrades were completed at Holly Tanks.
- Maintenance agreement with tank maintenance company was established for all five steel tanks.
- Earthquake-sensing valves were installed as part of our emergency preparedness program at all tank and reservoir facilities except for the Brown Reservoir.
- Continuous chlorine analyzers were installed at all production sources.
- Major upgrades to our SCADA system were completed to allow continuous monitoring and alarms on additional components of our production and distribution system.
- Permanent repairs and pipeline replacement were completed on the House Tunnel and the High/Low Pressure Tunnel production sources.
- The Vosburg booster pump was replaced with a new 25 HP submersible unit.

The total estimated costs for remaining projects as revised and updated by the General Manager in the 2007 Revision were:

1. Pipeline Improvements	\$3,128,000
2. Pump Station Improvements	\$ 190,000
3. Tunnels	\$ 321,000
4. Other Improvements	\$ 189,000
5. Planned Maintenance	<u>\$ 542,000</u>
Total	\$4,370,000

The difference between the 2005 costs and 2007 costs is an increase of \$1,187,400. The net increase was attributed to the following factors:

- Adjustment of previous costs to reflect inflationary and other factors in current project costs.
- A significant increase in pipeline construction costs based on bids for current projects.
- The estimated cost of remaining projects after removing completed projects and adding new projects identified since the master plan was adopted.

The following projects have been completed since the 2007 revision:

- All five steel tanks have been refurbished as necessary to maintain “as-new” condition.
- K-3 Well pump inspected and lowered 20 feet.
- New main installed connecting K-3 Well with the Wilcox Reservoir.
- Installed replacement mains in Kinneloa Mesa area.
- Replaced chlorine generators at two sites with Chlortec[®] units.
- Installed earthquake-sensing valve at the Brown Reservoir as part of our emergency preparedness program.
- Replaced pipeline in a portion of Villa Knolls Drive.
- Continuing upgrades to our SCADA system were completed to allow continuous monitoring and alarms on additional components of our production and distribution system.
- Solar power and SCADA installed at Brown Reservoir.
- Completed joint emergency interconnect project with Pasadena at two locations.
- Purchased additional emergency generators for three facilities.
- Installed utility electrical service at the East Tank to supplement existing solar power supply.
- Rebuilt Wilcox Reservoir 75 HP booster pump and motor.
- Rebuilt Pasadena Glen booster pump and motor.

- Installed replacement mains in Windover Road and portions of Sierra Madre Villa Avenue.
- Installed replacement connection and valves at the Vosburg Reservoir.
- Installed Variable Frequency Motor Control on K-3 Well pump.
- Replaced and added valves on main line on Villa Heights Road in East Tank pressure zone.
- Upgraded Chlorine analyzer at K-3 Well to include pH measurement.
- Replaced water depth measuring tube at Wilcox Well.
- Converted PCIC Interconnection facility to radio-based telemetry system.
- Rebuilt two of the Eucalyptus booster pumps.
- Installed transponders for radio reading of customer water meters.

The total estimated costs for remaining projects as revised and updated by the General Manager in the 2014 Revision were:

1. Pipeline Improvements	\$2,564,000
2. Pump Station Improvements	\$ 520,000
3. Tunnels	\$ 361,000
4. Other Improvements	\$ 105,000
5. Planned Maintenance	<u>\$ 397,000</u>
Total	\$3,947,000

The difference between the 2007 costs and 2014 costs is a decrease of \$423,000. The net decrease is primarily attributed to the completion of many master plan projects during the past seven years offset by the higher costs of some of the remaining projects. The overall cost of completing the master plan as compared to the original 2000 master plan is subject to the following factors:

- Adjustment of the previous costs of uncompleted projects to reflect inflationary and other factors.
- Adjustment of the previous costs based on the bidding results of similar projects.
- The estimated cost of remaining projects after removing completed projects and adding new projects identified since the master plan was adopted.

The following major projects have been completed since the 2014 revision:

- Delores Tunnel pipeline repairs
- Far Mesa Tunnel pipeline repairs
- Sierra Madre Villa water main replacement between Vosburg and Barhite Streets
- Barhite Street water main replacement east of Sierra Madre Villa
- Pasadena Glen access road water main replacement
- SCADA HMI/ touch panels
- SCADA maintenance and upgrades
- East Tank-West Tank connector pipeline
- Standby generator for Vosburg pump station
- Standby generator for Sage Tank
- Testing and maintenance of all system and fire hydrant valves and replacement of defective valves
- Vosburg Reservoir pump station replacement

The total estimated costs for remaining projects as revised and updated by the General Manager in this 2018 Revision are:

1. Pipeline Improvements	\$ 2,955,000
2. Pump Station Improvements	\$ 90,000
3. Tunnels	\$ 361,000
4. Other Improvements	\$ 140,000
5. Planned Maintenance	<u>\$ 397,000</u>
Total	\$ 3,943,000

The difference between the 2014 costs and 2018 costs is a decrease of \$574,000. The net decrease is primarily attributed to the completion of many master plan projects during the past four years offset by the higher costs of some of the remaining projects. The overall cost of completing the master plan as compared to the original 2000 master plan is subject to the following factors:

- Adjustment of the previous costs of uncompleted projects to reflect inflationary and other factors.
- Adjustment of the previous costs based on the bidding results of similar projects.
- The estimated cost of remaining projects after removing completed projects and adding new projects identified since the master plan was adopted.

In conclusion, many of the distribution and transmission facilities predate 1953, and are nearing the end of their useful service life. Originally, water facilities in the KID provided domestic supply, plus a fire flow of 750 gpm. As the population of the KID has grown over the years, the demand placed upon the entire system, including distribution and transmission mains, water sources, reservoirs, and pump stations have encroached upon the ability of the system to meet the required demands. The need for increased fire flow to meet the minimum Los Angeles County Fire Department requirements for every fire hydrant will require the KID to continue to construct improvements to the water system in the years ahead. Although many projects identified in the Water Master Plan adopted in 2000 and subsequent revisions have been completed, failure to continue to undertake the expenditures for the remaining projects leaves the KID vulnerable to serious and sustained service failure in the event of natural disaster or unanticipated breakage. Moreover, the cost to replace facilities and pipelines under non-optimal emergency conditions is likely to be much higher than if done under a planned program.

As a footnote to this 2018 Revision, it should be noted once again that this Water Master Plan was primarily developed to address fire flow issues and general emergency preparedness issues that were raised after the 1993 firestorm. Although many operational improvements are gained through completion of recommended projects, this Master Plan does not address many worthwhile projects that would improve the operational efficiency and reliability of the production and distribution system. For example, the Wilcox Well is no longer a major production facility due to declining pumping levels in the Raymond Basin and production level from the tunnels has also been declining due to lower average rainfall. That has made the KID increasingly dependent on a single production source – the K-3 Well. If the current conditions continue or worsen in the years ahead, the K-3 Well may not be able to meet our production demands for normal or emergency conditions. Therefore, the KID staff will continue to examine possible new production sources such as drilling a new well and/or constructing a connection with Foothill Municipal Water District to receive imported water from the Metropolitan Water District. However, the cost of developing new production sources is not currently reflected in this Master Plan. Therefore, unless additional funding sources are identified, voluntary or mandatory conservation programs may continue to be necessary in the future to avoid major additional capital expenditures not included in this revision of the Master Plan.

**WATER MASTER PLAN
FOR
THE KINNELOA IRRIGATION DISTRICT
TABLE OF CONTENTS**

WATER MASTER PLAN EXECUTIVE SUMMARY2

SECTION

1.0 Introduction, Purpose, and History 9
 1.1 Introduction..... 9
 1.2 Purpose..... 9
 1.3 History..... 9

2.0 System Description 11
 2.1 General..... 11
 2.2 Water Sources 11
 2.2.1 Water Wells 11
 2.2.2 Tunnels..... 12
 2.2.3 Spreading Credit and Leased Water Rights 13
 2.2.4 Imported Water 13
 2.2.5 Interconnections with City of Pasadena..... 14
 2.2.6 Portable Booster Pumps and Generators..... 14
 2.3 Reservoirs 15
 2.4 Booster Pumping Facilities 16
 2.5 Piping 16
 2.5.1 Existing Piping..... 16
 2.5.2 Future Piping..... 16

3.0 Existing Service Demands 18

4.0 Future Development..... 19
 4.1 General..... 19
 4.2 Doyne Road Development..... 19
 4.3 Potential Future Well Sites 19

5.0 Capacity Charge Improvement Fee 20

6.0 Service Demands 21
 6.1 Existing Service Demands 21
 6.2 Future Service Demands 22

7.0 System Improvements..... 25
 7.1 General..... 25
 7.2 Piping 25
 7.3 Booster Pump Stations..... 26
 7.3.1 Existing Booster Pump Stations 26
 7.3.2 Proposed Booster Pump Stations 28

**WATER MASTER PLAN
FOR
THE KINNELOA IRRIGATION DISTRICT
TABLE OF CONTENTS
(continued)**

SECTION

7.4	Tunnels.....	28
7.4.1	High Pressure Tunnel.....	28
7.4.2	Low Pressure Tunnels.....	28
7.4.3	House Tunnel	28
7.4.4	Delores Tunnel.....	29
7.5	Other Improvements	29
7.5.1	General.....	29
7.5.2	Additional Improvements	30
8.0	Planned Maintenance Program	31
9.0	Project Priorities.....	32
10.0	Cost Estimates for Required Improvements	33
10.1	Pipelines.....	33
10.2	Booster Pump Station Improvements	34
10.3	Tunnel Improvements	35
10.4	Costs of Other Improvements	36
10.5	Total Costs	36
<u>APPENDIX</u>	37
Exhibit I	Reservoir Improvements.....	38
Exhibit II	Schematic of Kinneloa Irrigation District Water System	44
Exhibit III	Fire Preparedness Policy.....	46

KINNELOA IRRIGATION DISTRICT
WATER MASTER PLAN

1.0 INTRODUCTION, PURPOSE, AND HISTORY

1.1 *Introduction*

The Kinneloa Irrigation District (KID) is a State irrigation district which owns and operates a water system in the north-central part of the Los Angeles County with the city limits of Pasadena on the west, south, and east sides and the Angeles National Forest to the north. The service area of the District covers an area of approximately 500 acres. The District additionally encompasses a watershed area north of the District. The KID serves a population of approximately 1,900 and there are 587 active metered services in the District's service area as of this revision. Additionally, it is the KID's responsibility to provide fire protection water to its customers. The District maintains 115 fire hydrants.

Revenue for the KID is derived almost exclusively from the sale of water.

1.2 *Purpose*

The purpose of this Master Plan is to describe the existing water system facilities within the KID, identify weaknesses within the system, recommend improvements, prioritize the necessary improvements, and determine cost estimates for implementing the improvements. This plan will also identify undeveloped land within the KID and assess potential for future development of that land.

1.3 *History*

The Kinneloa Irrigation District, originally formed in 1953, is a state irrigation district established pursuant to Division 11 of the California Water Code. A five member publicly elected Board of Directors governs it. The District water system presently serves about 582 households as well as a school, nursery, church, equestrian center and fire station. In 1974, the KID had 190 services.

In 1974 an improvement district was formed with the addition of the Mira Loma, Canyon Mutual, and Osborn Water Companies to the Kinneloa Irrigation District. The facilities in this area were replaced or upgraded to the current standards using funds from a bond issue. This added additional 225 services to the KID.

In 1978, the Wilcox Well was upgraded to provide additional production capacity for homes on the east side of the district.

In 1979, 24 homes were added on Villa Highlands Drive and Villa Knolls Drive by Falzone Development.

In 1983, Nordberg and Neimeyer developed the area known as Hastings Heights and provided lots for 27 homes.

In 1990, town homes were built by Dove Creek Development at a site near New York Drive and Altadena Drive which added 50 services.

In 2003, 21 building sites were completed in the Kinneloa Canyon area known as Kinneloa Ridge by Diamond-Segundo Development and 23 services are now active including two for watering common areas. Additional pumping and storage facilities were added to accommodate this development and to provide a benefit for the District.

Additionally, several individual lots have been developed to account for the 584 present metered services. Approximately 25 lots remained undeveloped including homes that were not rebuilt after the 1993 fire.

KINNELOA IRRIGATION DISTRICT

WATER MASTER PLAN

2.0 SYSTEM DESCRIPTION

2.1 *General*

The Kinneloa Irrigation District was historically divided into two distinct geographic areas. They are the east service area and the west service area, which are generally, divided by the Wilcox Canyon watercourse. However, the east and west service areas are now connected by pipelines between the following facilities: Holly Booster Pump Station, the East Tank, and the Vosburg Booster Station; K-3 Well pump on the west side with the Wilcox Reservoir on the east side; and the West Tank with the East Tank. These pipeline improvements have integrated the east and west service areas into a single system.

Almost all the services in the KID are residential services for single family homes. The need for irrigating hillsides on relatively large lots creates much of the demand. Services and meters range from 3/4" to 2" in size.

Within each service area are several pressure zones which are serviced by a piping network, reservoirs, booster pump stations, wells, and horizontal water tunnels. See Exhibit II for a schematic drawing of the existing KID system.

2.2 *Water Sources*

2.2.1 Water Wells

The KID owns five water wells. Two of these wells are operational and are the primary source of water for the District. Those wells are the Wilcox Well which supplies the Wilcox Reservoir and the K-3 Well which supplies the Eucalyptus and Wilcox Reservoirs. Both wells pump from the Raymond Basin. The District's adjudicated pumping allowance is 516 acre-feet per year plus an allowance for spreading. The current pumping allowance has been reduced by 30% to 361 acre-feet by informal agreement among water agencies to help maintain basin water levels. Both wells are equipped with deep-well, oil-lubricated, vertical turbine pumps and on-site generated sodium hypochlorite (0.8%) chlorinators with metering pumps for disinfection. Well status signals are received via radio telemetry and start-stop commands are based on reservoir levels and time-of-use schedules to take advantage of off-peak electricity rates. See Table 2.2A for a summary of well data.

**TABLE 2.2A
WELL DATA**

Well Name	Year Drilled & Depth	Casing Size (inches)	Motor Horsepower	2016-2017 Production
Wilcox Well	1924 500'	14"	100	5 acre-feet
K-3 Well	1965 700'	14" I.D.	125	557 acre-feet*

* Includes production of wholesale water sold to the City of Pasadena.

2.2.2 Tunnels

The KID owns and operates 15 water supply tunnels. The tunnels were originally constructed by hand in the 1800's and, in recent times, have supplied groundwater to the KID system and for spreading. Tunnel flow rate varies continuously according to the time of year and some tunnels are not currently producing water due to drought conditions. Tunnel water is delivered via gravity. Table 2.2B summarizes the tunnels, their status, and production.

**TABLE 2.2B
TUNNEL SUPPLIES**

Tunnel Name	Status	2016-2017 Production
High & Low-Pressure Tunnels (4)	Currently in Service – feeds the Holly Tanks	41 acre-feet
House Tunnel	In service – feeds the Holly Tanks	0 acre-feet (No flow during this period)
Eucalyptus Tunnel	In service – feeds the Eucalyptus Reservoir	39 acre-feet
Long Tunnel	In service for spreading	34 acre-feet
Delores Tunnel	In service – feeds the Vosburg Reservoir or used for spreading	12 acre-feet
Far Mesa Tunnels (2)	In service – feed the Glen Reservoir	29 acre-feet
Tent Tunnel	In service for spreading	2 acre-feet
Falls Tunnel	In service for spreading	Measured for spreading credit only
Diversion Tunnel	In service for spreading	Measured for spreading credit only
Winifred Tunnels (2)	Not in service	Not measured

Depending on the season of the year, the tunnels are each capable of supplying anywhere from a few gallons per minute up to a hundred gallons per minute or more.

The tunnels have traditionally been a low-cost source of water for the KID. However, the firestorm of October 1993 damaged the High and Low-Pressure Tunnel delivery pipelines. The rainstorms of the winter of 1993-94 further damaged the High and Low-Pressure Tunnel pipelines. The High and Low-Pressure Tunnel pipelines were further damaged in the winter storms of 1994-95. Because of the natural disasters, temporary repairs were made to return these sources to service and permanent repairs were made in 2006. Old age, rockslide damage, and rain storm runoff washed out the Delores Tunnel delivery pipeline. This pipeline was replaced in 2001 after being out of service since 1979.

Because of the age of the tunnels and their vulnerability to damage from natural causes, the tunnel supply is not considered as a reliable source of supply for calculating available water source supply. In this respect, the tunnel supply should be thought of as a reserve or "back-up" supply.

2.2.3 Spreading Credit and Leased Water Rights

The KID receives spreading credit for surface water diversion to the Sierra Madre Villa and the Kinneloa Canyon Debris Basins. Total credit from these sources for 2016-2017 was 130 acre-feet. Leased Water Rights are available in some years from other water agencies to supplement our adjudicated pumping rights. Water from these sources is produced by the K-3 and Wilcox Well pumps and is included in the totals for those production sources.

2.2.4 Imported Water

The Kinneloa Irrigation District is a member of the Foothill Municipal Water District (FMWD) which supplies imported water from the Metropolitan Water District of Southern California (MWD) to eight retail agencies in the area. Although there is no physical pipeline connection from FMWD to the KID, at this time, arrangements could be made to deliver the water through the distribution systems of an adjacent water agency if supplemental water is needed in the future.

2.2.5 Interconnections with the City of Pasadena

The KID has six interconnections with the City of Pasadena to deliver excess KID water and/or to receive water in the event of an emergency. These interconnections are shown in Table 2.2C. The capacity of interconnections 3 and 5 was increased in 2008 as a joint project with the City of Pasadena.

TABLE 2.2C
INTERCONNECTIONS WITH CITY OF PASADENA

ID	Location	Description	Size	Capacity	Purpose
1	1776 Kinneloa Canyon Road	KID-Eucalyptus (1125 HWL) to Pasadena-Sheldon (1050 HWL)	4"	800 gpm	Deliver excess KID water to City of Pasadena
2	1727 Kinneloa Canyon Road	Pasadena-Calaveras (1209 HWL) to KID-Eucalyptus (1125 HWL)	4"	650 gpm	Emergency interconnection to KID-Eucalyptus (K-3 Well System)
3	3560 Ranch Top Road	Pasadena-Don Benito (1432 HWL) to KID-Vosburg (1430 HWL)	8"	800 gpm	Emergency interconnection to KID-Vosburg & Brown/Glen System and to deliver excess KID water to Pasadena
4	2999 New York Drive	Pasadena-Sheldon (1050 HWL) to KID-Wilcox Reservoir (944 HWL)	6"	1200 gpm	Emergency interconnection to KID-Wilcox Well/Wilcox Reservoir
5	3410 Fairpoint Street	KID-Vosburg (1430 HWL) to Pasadena-Murray System (1176 HWL)	8"	400 gpm	Emergency interconnection to Pasadena-Murray/Calaveras System and to deliver excess KID water to Pasadena
6	2650 New York Drive	Pasadena-Calaveras (1209 HWL) to KID-Eucalyptus (1125 HWL)	8"	1500 gpm	Emergency interconnection to KID to provide additional fire protection for Dove Creek Town Homes

2.2.6 Portable Generators

The KID currently has six (6) diesel-powered trailer mounted portable generators to supply emergency power to any of the KID facilities. Although the generators can be moved, each generator is dedicated to a facility that is critical in the event of a power failure due to any cause.

2.3 Reservoirs

The KID operates and maintains ten (10) water storage tanks and reservoirs. Overflow elevations range from 940 feet to 1,637 feet. Reservoir data is shown in Table 2.3A.

**TABLE 2.3A
RESERVOIR STORAGE DATA**

Reservoir Name	Number & Capacity	Zone Served	High Water Level	Construction
Eucalyptus	1 - 0.180 MG	Eucalyptus	1,125'	Partially Buried Reinforced Concrete
Wilcox	1 - 1.125 MG	N/A	940'	Partially Buried Concrete
Holly Tanks	2 - 0.150 MG	Holly/Sage	1,460'	Circular, Welded Steel Aboveground
Vosburg	1 - 1.250 MG	Vosburg	1438	Partially Buried Reinforced Concrete
Glen	1 - 0.125 MG	Glen/Brown	1,265'	Buried Reinforced Concrete
Brown	1 - 0.125 MG	Glen/Brown	1265'	Buried Reinforced Concrete
East Tank	1 - 0.150 MG	East/West	1,637'	Circular Welded Steel, Aboveground
Sage Tank	1 - 0.225 MG	Holly/Sage	1,457'	Circular Welded Steel, Aboveground
West Tank	1 - 0.500 MG	East/West	1,634'	Circular Welded Steel, Aboveground
Total Storage	3.980 MG			

MG = Million Gallons

Existing storage capacity by zone is shown in Table 2.3B.

**TABLE 2.3B
STORAGE CAPACITY BY SERVICE ZONE**

Zone	Storage Capacity
Eucalyptus	0.180 MG
Holly/Sage	0.525 MG
Glen/Brown	0.250 MG
East/West Tanks	0.650 MG
Vosburg	1.250 MG

2.4 *Booster Pumping Facilities*

The KID operates and maintains five (5) separate booster-pumping facilities. All booster pumps are operated via telemetry and based upon reservoir levels. Booster pump facility data is shown in Table 2.4.

**TABLE 2.4
BOOSTER PUMPING FACILITIES**

Facility Name	No. of Pumps	Horsepower	Head (feet)	Approx. Capacity (gpm)	Service
Eucalyptus	3	50 HP each	346'	400 each	Eucalyptus Reservoir to the Holly/Sage Tanks
Holly	2	20 HP each	205'	200 each	Holly Tanks to East Tank***
Vosburg	3	25 HP	195'	300	Vosburg Reservoir to East/West Tanks****
Glen	1	25 HP	165'	345	Glen Reservoir to Vosburg Reservoir
Sage	2	25 HP each	205'	400 each	Sage Tank to East/West Tanks
Wilcox Reservoir	1*	75 HP	325'	515	Wilcox Reservoir to Brown/Glen Reservoirs
		75 HP	490'	360	Wilcox Reservoir to Vosburg Reservoir
	2**	50 HP & 75 HP	325'	650	Wilcox Reservoir to Brown/Glen Reservoirs
		50 HP & 75 HP	490'	433	Wilcox Reservoir to Vosburg Reservoir

* Condition when pumping to either Brown/Glen Reservoirs or Vosburg Reservoir with just the 75 HP pump.

** Condition when pumping to either Brown/Glen Reservoirs or Vosburg Reservoir with both pumps.

*** Holly Booster Station was taken out of service in 2016.

****Vosburg Booster Replacement Project was completed in 2016.

2.5 *Piping*

2.5.1 Existing Piping

There are approximately 70,000 Linear Feet of transmission and distribution mains in the KID service area. The pipes range in size from 1" to 16-inches in diameter. Piping materials include galvanized steel, CML and CMC steel, asbestos cement (AC), ductile iron (DI) and AWWA C-900 PVC. There are approximately 115 fire hydrants in the system ranging in size from 2 ½" to 6" x 4" x 2 ½". **All the galvanized steel piping is old and obsolete. Some of the existing pipe is old and inadequate to provide current revised requirements for fire service.**

2.5.2 Future Piping

Traditionally, piping in the KID was sized to provide for fire flows of 750 gpm. The firestorm of October 1993 exposed this pipeline delivery capacity weakness. As a result, the KID Fire Preparedness Policy now requires that all new facilities, including pipe, be sized to support a fire flow of 1,250 gpm with a 20-psi minimum

residual. This represents a 500 gpm increase to the original system design capacity of 750 gpm fire flow at 20 psi minimum residual pressure. **Some areas of the existing system meet the new requirements; however, portions of the distribution system will provide only the minimum original system design fire flows. Some fire hydrants supply less than the original design capacity of 750 gpm.** Additionally, the County of Los Angeles has required 2000 gpm or more fire flow for some of the new larger homes currently being built where fire sprinklers are required. Future pipeline projects may need to be sized to support this flow.

KINNELOA IRRIGATION DISTRICT
WATER MASTER PLAN

3.0 EXISTING SERVICE DEMANDS

The KID services approximately 587 customers with a population of approximately 1,900. Service sizes range from 3/4" to 2". All services within the District are residential with the following exceptions:

- High Point Academy
- Magic Growers
- Los Angeles County Fire Station No. 66
- Pasadena Church of Christ
- Equestrian Center

The KID produces water from two wells and several tunnels. The 2016-2017 production from those sources is shown in Table 3.0.

TABLE 3.0
TUNNEL AND WELL PRODUCTION
DELIVERED TO DISTRIBUTION SYSTEM 2016-2017

Source	2016-2017 Production
K-3 Well	556.9 acre-feet*
Wilcox Well	5.1 acre-feet
High and Low-Pressure Tunnels	40.9 acre-feet
Far Mesa Tunnel	28.5 acre-feet
House Tunnel	0 acre-feet (No flow during this period)
Eucalyptus Tunnel	39.0 acre-feet
Delores Tunnel	11.7 acre-feet
TOTAL	682.0 acre-feet

* Includes production of wholesale water sold to the City of Pasadena.

Additional production from tunnels is delivered for spreading in the Raymond Basin. Water delivered for spreading can be recovered by the District by increased pumping allotments or can be sold to other water purveyors. In 2016-2017, water delivered for spreading by the KID amounted to 130 acre-feet. The sources of this water in a year can include the High and Low-Pressure Tunnels, the Long Tunnel, Delores Tunnel, Diversion Tunnel, Falls Tunnel, Winifred Tunnels, Tent Tunnel, and surface runoff from watershed owned by the District into the Glen Wash, Kinneloa Canyon and the Sierra Madre Villa Debris Basins.

KINNELOA IRRIGATION DISTRICT
WATER MASTER PLAN

4.0 FUTURE DEVELOPMENT

4.1 *General*

A report dated July 2, 1990, prepared for the KID by ASL Consulting Engineers identified a potential for 95 new dwelling units within the KID boundaries. The report identified 57 potential units which would be built by developers and another 38 units which would most probably be constructed as single units and not part of a development project. Since that time all major development work has been completed except for a potential development in the Doyne Road area as described below and the building or re-building of approximately 25 homes on individual vacant lots.

4.2 *Doyne Road Development*

Hydraulic studies were completed for a potential development (Tract no. 44323) that was planned to be constructed in the south-central area of the KID. The new tract was to be served from the existing Holly/Sage Zone. The development required the grading of 8 undeveloped lots ranging in size from 0.60 acres to 3.0 acres. Total area was approximately 13 acres in the final development plan. Water system improvements for this tract were to include new distribution and transmission mains and a new booster pump station at the Wilcox Reservoir. However, after grading was completed for 8 lots, the property was purchased from the developer by an individual who subsequently abandoned plans for the tract and combined the lots into two separate parcels. As of January 2018, the status for building homes on these parcels is not known. There is also an adjacent two-acre parcel under separate ownership on which the home was not rebuilt after it was destroyed in the 1993 Kinneloa-Altadena firestorm.

4.3 *Potential Future Well Sites*

The KID has a few potential well sites within the District boundaries. The Equestrian Center north of New York Drive was acquired by Los Angeles County and incorporated into the Eaton Canyon Natural Area. The park status will allow for a well site for the District. The area of Wilcox Canyon, north or south of the Wilcox Reservoir also offers potential for a future well site. Finally, a site on Outpost Lane owned by the City of Pasadena is a possible location for a joint well project.

KINNELOA IRRIGATION DISTRICT
WATER MASTER PLAN

5.0 CAPACITY CHARGE IMPROVEMENT FEE

Improvements were made to the KID water system during the Dove Creek Development in 1987-1990. These improvements included improvements to the K-3 Well, Eucalyptus Reservoir, and piping in New York Drive. At the time of these improvements, the KID decided to build in reserve system capacity and redundancy beyond that required by the Dove Creek Development. Because the cost of the improvements was beyond what was required by the Dove Creek Development, the KID funded the marginal increase of the cost of the improvements beyond the Dove Creek Development requirements.

To recover the cost of the reserve capacity, the Board of Directors of the KID in 1990 instituted a Capacity Charge Improvement Fee on all future development in the District. The fee is \$3,000.00 per lot and is only charged for existing or newly created lots that do not have an existing water service. This fee is in addition to reimbursement for the cost of installing the new water service and required system improvements.

KINNELOA IRRIGATION DISTRICT
WATER MASTER PLAN

6.0 SERVICE DEMANDS

6.1 *Existing Service Demands*

Average day and maximum day service demands are based on water delivery records for the drought year (September 1990 – September 1991). Average day demand is the total annual water delivered as recorded by the individual customer water meters averaged over 365 days per year. Maximum day demand is the maximum day total water delivered, averaged over 24 hours. Maximum day delivery data is not available for individual customer water meters. Customer water meter demand is only recorded monthly. Individual pumping facility production and reservoir levels are recorded daily at roughly the same time each day. Individual facility records are used to determine maximum day total water delivery. To establish a comparison between average day and maximum day demands it is necessary to compare average day and maximum day demands of the same representative service area. Average day and maximum day data is available for the total Holly and East Tank service area.

The record data for this service area indicates the following:

- 237 services
- 189 total acres
- Annual delivery of 134,990 billing units (B.U.)
- Maximum day delivery (7/29/1990) of 1,029 billing units

Average Day Demand

$$\frac{134,990 \text{ B.U.}}{189 \text{ Acre/Year}} \times \frac{748 \text{ Gal.}}{\text{B.U.}} \times \frac{1 \text{ Year}}{365 \text{ Days}} \times \frac{1 \text{ Day}}{1,440 \text{ Min.}} = \frac{1.02 \text{ Gal/Min}}{\text{Acre}}$$

OR:

$$\frac{134,990 \text{ B.U.}}{237 \text{ Services}} \times \frac{748 \text{ Gal.}}{\text{B.U.}} \times \frac{1 \text{ Year}}{365 \text{ Days}} \times \frac{1 \text{ Day}}{1,440 \text{ Min.}} = \frac{0.81 \text{ Gal/Min}}{\text{Service}}$$

Maximum Day Demand

$$\frac{1,029 \text{ B.U.}}{189 \text{ Acre/Day}} \times \frac{748 \text{ Gal.}}{\text{B.U.}} \times \frac{1 \text{ Day}}{1,440 \text{ Min.}} = \frac{2.83 \text{ Gal/Min}}{\text{Acre}}$$

OR:

$$\frac{1,029 \text{ B.U.}}{237 \text{ Services}} \times \frac{748 \text{ Gal.}}{\text{B.U.}} \times \frac{1 \text{ Day}}{1,440 \text{ Min.}} = \frac{2.26 \text{ Gal/Min}}{\text{Service}}$$

The ratio of the maximum day demand over the average day demand is the maximum day factor. For the existing Holly and East Tank Zone, the maximum day factor is as follows:

$$\frac{2.83}{1.02} = 2.77$$

Existing service demands for the number of services in 2007 for each zone were based on the calculated average day and maximum day demand factors for the Holly and East Tank Zone and are shown in Table 6.1.

TABLE 6.1
SERVICE DEMANDS BY ZONE IN THE
KINNELOA IRRIGATION DISTRICT

Service Zone	No. of Services	Average Day Demand 0.81 gpm/service (gpm)	Maximum Day Demand 2.26 gpm/service (gpm)
Eucalyptus	62	51	141
Holly/Sage	190	154	430
East/West*	86	97	257
Brown/Glen	70	57	159
Vosburg	192	156	434

* West Tank service demand based on 1.85 gpm/acre average day and 5.12 gpm/acre maximum day demands and a 23.3-acre service area. East and West service zones were combined in 2017.

6.2 *Future Service Demands*

Future service demands for various zones in the KID system were calculated based on the number of existing services, the planned additional services and the estimated future customer service demands. Planned additional services in the KID service area have a higher potential for water use than the existing customer services. Planned additional services are estimated to be comparable to the Shaw Ranch Estate type properties. Shaw Ranch record data indicates the September 1990 – September 1991 annual demand for 24 active services, serving 16.94 acres was a total of 21,984 billing units. Average day demand for planned future services is calculated as follows:

$$\frac{21,984 \text{ B.U.}}{16.94 \text{ Acre/Yr}} \times \frac{748 \text{ Gal.}}{\text{B.U.}} \times \frac{1 \text{ Year}}{365 \text{ Days}} \times \frac{1 \text{ Day}}{1,440 \text{ Min.}} = \frac{1.85 \text{ gpm}}{\text{Acre}}$$

OR:

$$\frac{21,984 \text{ B.U.}}{24 \text{ Services}} \times \frac{748 \text{ Gal.}}{\text{B.U.}} \times \frac{1 \text{ Year}}{365 \text{ Days}} \times \frac{1 \text{ Day}}{1,440 \text{ Min.}} = \frac{1.30 \text{ gpm}}{\text{Service}}$$

Maximum day demand for planned future services is the average day demand multiplied by the developed maximum day factor as follows:

$$1.85 \text{ gpm/acre} \times 2.77 = 5.12 \text{ gpm/acre}$$

OR:

$$1.30 \text{ gpm/service} \times 2.77 = 3.60 \text{ gpm/service}$$

For master planning and calculation of future system demands, 5.12 gpm/acre or 3.60 gpm/service will be used to calculate future service demands per zone. Table 6.2A shows the future service demand of the potential new services by zone.

TABLE 6.2A
FUTURE SERVICE DEMANDS BY ZONE IN THE
KINNELOA IRRIGATION DISTRICT

Service Zone	No. of Future Services	Average Day Demand 1.3 gpm/service (gpm)	Maximum Day Demand 3.6 gpm/service (gpm)
Eucalyptus	1	1.3	3.6
Holly/Sage	16	21.0	57.6
East/West*	2	2.6	7.2
Brown/Glen	8	11.0	28.8
Vosburg	5	7.0	18.0

*East and West service zones were combined in 2017.

Table 6.2B shows the sum of the water demand for existing services in Table 6.1 and the potential new services in Table 6.2A.

TABLE 6.2B
TOTAL FUTURE SERVICE DEMANDS BY ZONE
IN THE KINNELOA IRRIGATION DISTRICT

Service Zone	Total Services	Average Day Demand (gpm)	Maximum Day Demand (gpm)
Eucalyptus	63	52	145
Holly/Sage	206	175	488
East/West*	87	98	261
Brown/Glen	78	68	188
Vosburg	197	163	452

* West Tank service demand based on 1.85 gpm/acre average day and 5.12 gpm/acre maximum day demands and a 23.3-acre service area.

KINNELOA IRRIGATION DISTRICT
WATER MASTER PLAN

7.0 SYSTEM IMPROVEMENTS

7.1 *General*

The KID was formed in 1953. Many of the distribution and transmission pipelines predate 1953 and are nearing the end of their useful service life. For the purposes of this plan, the useful service life of the pipelines is set at 50 years. Development of excessive numbers of leaks and/or reduced pipeline capacity are two of the indications of pipelines at the end of their useful service life.

Originally, water mains in the KID provided domestic supply plus a fire flow of 750 gpm. The existing distribution system meets the original fire flow design criteria. The firestorms of October 1993 exposed the KID pipeline delivery capacity weakness. As a result, the KID adopted a Fire Preparedness Policy which requires new water mains to be sized to provide 20 gpm per service, plus a fire flow of 1,250 gpm each at two fire hydrants simultaneously.

As the population of the KID has grown over the years, the demands placed upon the entire system, including distribution and transmission mains, water sources, reservoirs, and pump stations have encroached upon the ability of the system to meet the required demands. Population growth, plus the need for increased fire flow to provide adequate fire protection will require the KID to construct improvements to the KID water system.

7.2 *Piping*

In April 1996, ASL Consulting Engineers conducted a study for the KID to identify water main improvements required to increase water system capabilities to deliver domestic demands plus 1,250 gpm fire flows.

All pipes that develop chronic leaks should be replaced to decrease waste of water and to achieve overall lower operational costs.

Pipelines which have become inaccessible due to development or are traversing private property in easements should also be replaced if practical and/or possible. Pipelines should be upsized where required to meet the fire preparedness goals. Upsizing is to be determined by hydraulic modeling and verified by field-testing.

Many projects have been completed since the original master plan. The remaining projects that are listed in Table 7.2 provide a remedy for the following conditions:

- Chronically leaking pipes.
- Pipe requiring upgrade to meet domestic demand and fire preparedness goals.
- Piping which has become inaccessible due to development or crosses private property in easements.

TABLE 7.2
REQUIRED WATER MAIN REPLACEMENTS
TO MEET 1,250 GPM FIRE FLOW AND
450 FEET VEHICULAR DISTANCE

Main Size	Description	
	From	To
8"	Sierra Madre Villa at Windover Rd.	Corner of 2090 & 2060 Villa Heights Rd..
8"	Country Lane	Southeast Corner of 1747 Country Lane
12"	Glen Reservoir	Intersection Villa Highlands & Sierra Madre Villa Includes Slope from Pasadena Glen to Barhite
8"	Kinclair Dr.	Behind 2150 Kinclair Dr.
8"	Kinclair Dr.	#4 Cricklewood Path
8"	Kinneloa Canyon Rd.	Behind 2044 Piccadilly Ln.
8"	Intersection of Vosburg St. & Lower Pasadena Glen Rd.	In front of 1658 Pasadena Glen Rd.

7.3 *Booster Pump Stations*

7.3.1 Existing Booster Pump Stations

The KID presently has sufficient booster pump capacity to provide for domestic demands. The 1,250 gpm fire flow requires supplementing booster station flow with gravity flow from reservoirs.

There are booster pump facilities located at the Eucalyptus Reservoir, Holly Tanks, Sage Tank, Wilcox Reservoir, Glen Reservoir and at the Vosburg Reservoir. The booster pumps at the Eucalyptus Reservoir were replaced with high efficiency vertical turbine units in 2002 as part of the system improvements needed for the Kinneloa Ridge Development.

The booster pumps at Holly Tanks are scheduled to be removed since the construction of new facilities at the Vosburg Reservoir provide redundant operation.

The three booster pumps at the Vosburg Reservoir are high efficiency vertical turbine units which were installed in 2016.

Table 7.3A compares the required booster pump station capabilities with existing booster pump station capabilities. Required booster pump station capabilities will supply maximum day demand with an off-peak 16-hour maximum pumping period.

Required Booster Pump Capacity: Each booster facility must provide capacity to serve all zones in the system above the booster station based on 16-hour maximum pumping period.

- Eucalyptus Booster Capacity is 1017 gpm
- Vosburg Booster capacity is 300 gpm
- Glen Booster Capacity is 785 gpm
- Sage Booster Capacity is 286 gpm
- Wilcox Booster Capacity is 1067 gpm

TABLE 7.3A
COMPARISON OF REQUIRED BOOSTER PUMP CAPACITIES

Booster Station	Required Future Pump Capacities (gpm)	Existing Capacity (gpm)*	Additional Capacity Required (gpm)
Eucalyptus	1,017	800	217
Vosburg	107	300	0
Glen	785	345	440
Sage	286	400	0
Wilcox Reservoir	1,067	650	417

* Existing capacity reflects normal operation. Some sites have additional capacity if all boosters are used simultaneously.

Table 7.3B shows the proposed booster pump improvements to increase efficiencies and/or capacities and provide improved redundancy.

TABLE 7.3B
PROPOSED BOOSTER IMPROVEMENTS

Booster Station	Description
Glen	Increase booster pump capacity.
Wilcox Reservoir*	Increase booster pump capacity.

* Pipeline upgrades also required to reduce pumping head.

7.3.2 Proposed Booster Pump Stations

Although the plan for an eight-home tract on Doyne Road has been abandoned, the building of two or more homes on Doyne Road may require additional booster pump capacity at the Wilcox Reservoir and other pipeline upgrades. The necessary improvements have already been made at the Eucalyptus Booster Pump Station in conjunction with the Kinneloa Ridge Development and the main on Doyne Road was replaced as part of the Kinneloa Mesa pipeline improvement project.

7.4 *Tunnels*

7.4.1 High Pressure Tunnel

The High-Pressure Tunnel pipeline is currently in service and supplies water to the Holly Tanks or the West Tank. The High-Pressure Tunnel pipeline was damaged during the firestorms of October 1993. Additional damage occurred from mudslides during the rainy season of subsequent years. In 1994, the High-Pressure Tunnel pipeline was repaired with FEMA funding. In the winters of 1994-95 and 2004-05, the High-Pressure Tunnel pipeline was again damaged by mudslides. The KID applied for FEMA funding because of the disaster declaration after the 2004-2005 storms and permanent repairs were completed in 2006 using a combination FEMA funds and KID funds.

7.4.2 Low Pressure Tunnels

Pipelines delivering water from the Low-Pressure Tunnels to the Holly Tanks have been out of service at various times since 1993. Both low pressure tunnel pipelines were damaged during the fire storms of October 1993. Further damages occurred from mudslides during the rainy seasons of subsequent years. In 1994, the lower Low-Pressure Tunnel pipeline was replaced using FEMA funding. In subsequent rainy seasons, the tunnel has since been buried by mudslides. The storms of 2004-2005 further damaged the lines. The KID applied for FEMA funding to repair the lines to take advantage of the low-cost water supply. The upper low-pressure tunnel pipeline was replaced and put back in service in 2006. The lower low-pressure tunnel was excavated to the tunnel face, but further work has been suspended due to lack of funding and safety concerns.

7.4.3 House Tunnel

The House Tunnel pipeline was also damaged in the 2004-2005 storms. The damaged section was replaced with flexible hose suspended from a cable and the rest of the pipeline was inspected and repaired at two locations. Since most of the pipeline is galvanized steel and was installed decades ago, it is expected that the pipeline will need to be replaced within the next 20 years even if there is no further storm damage. The tunnel is not currently delivering water to the distribution system due to the drought.

7.4.4 Delores Tunnel

The Delores Tunnel was out of service between 1979 and 2001 due to rockslide and rain storm damage to the delivery pipeline. Although this pipeline was replaced in 2001 with flexible hose suspended from a cable for much of its length, it is still vulnerable to damage in the future. Therefore, it is expected that portions will need to be repaired or replaced within the time frame of this master plan. The tunnel is not currently delivering water to the distribution system due to the drought.

The required tunnel maintenance and improvements are listed in Table 7.4.

TABLE 7.4
REQUIRED TUNNEL MAINTENANCE AND IMPROVEMENTS

Tunnel	Description
High Pressure	Periodically inspect pipeline for potential damage from landsides. Inspect for leaks and repair or replace pipeline as needed.
Low Pressure	Periodically inspect pipeline for potential damage from landsides. Continue excavation of lower tunnel and complete new tunnel face and pipeline between the tunnel and the injector if tunnel flow is significant.
House	Periodically inspect pipeline for potential damage from landsides. Inspect for leaks and repair or replace pipeline as needed.
Delores	Periodically inspect pipeline for potential damage from landsides. Inspect for leaks and repair or replace pipeline as needed.

7.5 *Other Improvements*

7.5.1 General

Within Section 7 of this master plan, necessary improvements have been identified which would connect tunnel water supplies to the system and improve system hydraulics to meet a 1,250 gpm fire flow for two hours. Also, improvements to reservoirs have been identified which are necessary to meet a minimum 1,250 gpm fire flow for two hours plus domestic demands. This section will examine other necessary system improvements.

7.5.2 Additional Improvements

The KID has identified other capital improvements necessary to upgrade existing facilities to provide increased operational efficiency, greater margins of safety, address emergency preparedness issues and to decrease maintenance costs. Additional capital improvements are shown in Table 7.5.

TABLE 7.5
ADDITIONAL IMPROVEMENTS AS IDENTIFIED BY THE
KINNELOA IRRIGATION DISTRICT

Description
Upgrade SCADA hardware, software and communications radios to prevent obsolescence (OPS)
Replace obsolete on-site chlorine generators. (OPS)
Purchase 250 kw trailer-mounted generator to be used and Wilcox and K-3 (EP)
EP= Emergency Preparedness OPS= Operations Improvement

KINNELOA IRRIGATION DISTRICT
WATER MASTER PLAN

8.0 PLANNED MAINTENANCE PROGRAM

The KID has developed a Planned Maintenance Program for the KID’s water distribution system which extends the life of existing capital improvements. These items of work include pump overhauls, motor overhauls and replacements, reservoir recoating, reservoir roof repairs, upgrade interconnections with other agencies, purchase of small tools, upgrading various facilities, and office improvements. The items of work identified in this section are typically referred to as operations and maintenance items but due to relatively high cost they need to be budgeted in the same manner as capital improvements. Planned maintenance items identified by the staff are listed in Table 8.0 and are not in priority order.

TABLE 8.0
PLANNED MAINTENANCE PROGRAM ITEMS*

Item	Description	Est. Cost
1	Glen Reservoir - Install liner	\$30,000
2	Upgrading of Fire Hydrant Heads (\$500.00 to \$2,500 ea.)	\$34,000
3	Tunnel Maintenance (avg. \$7,000 per year for a 10-year period)	\$70,000
4	Valve Maintenance (replacement cost averages \$2,500 per valve)	\$25,000
5	Office Maintenance & Improvements: 1. Replace carpet and do interior painting; 2. Add storage shed to exiting concrete pad	\$40,000
6	Brown Reservoir - Install liner	\$30,000
7	Holly Tanks Erosion Control (All Phases)	\$140,000
8	Holly Boosters - Paint Booster Station	\$1,000
9	Wilcox Reservoir - Pump stand/other repairs	\$25,000
10	Service Area - Emergency prep. - install or replace “Blue Dot” Markers for Fire Hydrants	\$1,000
11	Wilcox Well - Modify dump line to dispose of water on site	\$1,000
	Total (Revised in 2018)	\$397,000

KINNELOA IRRIGATION DISTRICT
WATER MASTER PLAN

9.0 PROJECT PRIORITIES

Project priorities are based upon cost-benefit considerations. Projects that will realize higher revenues per unit cost are given a higher priority than projects that will realize lower revenue, or no revenue, per unit dollar spent. Priorities are also based upon increased fire protection, increased operational efficiencies and lower maintenance costs. Projects are listed in Table 9.0 in order of decreasing priority in each project category.

TABLE 9.0
CAPITAL IMPROVEMENT PROJECTS LISTED BY PRIORITY

Priority	Project	Description
1	Pipeline	Sierra Madre Villa from Windover Road to Corner of 2090 and 2060 Villa Heights Road
2	Pipeline	Replace service main in portion of Fairpoint Street from 3410 to last service at 3500 Fairpoint
3	Pipeline	Replace Brown/Glen line from corner of Fairpoint Street and Sierra Madre Villa to Barhite Street
4	Pipeline	Country Lane to Southeast Corner of 1747 Country Lane
5	Pipeline	Kinclair Drive to rear of 2150 Kinclair Drive
6	Pipeline	Kinclair Drive to #4 Cricklewood Path
7	Pipeline	Kinneloa Canyon Road to rear of 2044 Piccadilly Lane
8	Pipeline	Intersection of Vosburg St. and lower Pasadena Glen Rd. to front of 1658 Pasadena Glen Rd.
9	Pipeline	Replace service main in Edgecliff Lane from Villa Knolls Drive to cul-de-sac
10	Pipeline	1908 N. Kinneloa Canyon Rd. to intersection of Larmona Drive & Kinneloa Mesa Road (Doyne Road project)
11	Pipeline	Replace service main from Villa Knolls Drive to end of Hartwood Point Drive
12	Pipeline	Replace service main in Villa Mesa Dr. from Sierra Madre Villa Ave. to 3336 Villa Mesa Dr.
13	Pipeline	From Glen Reservoir to intersection of Villa Highlands and Sierra Madre Villa. Includes slope from Pasadena Glen to Barhite
14	Pipeline	Replace water main from Wilcox Well to Wilcox Reservoir
1	Tunnel	Construct permanent replacement pipeline section from High Pressure Tunnel to Holly and/or Sage Reservoir
2	Tunnel	Construct pipeline from lower Low-Pressure Tunnel to junction with High Pressure Tunnel Pipeline north of Kinneloa Debris Basin
3	Tunnel	Replace other tunnel pipelines as required
1	Booster	Replace the existing 50 HP oil lubricated booster pump at Wilcox Reservoir with a water lubricated pump
2	Booster	Install additional booster pump and new electrical at Wilcox Reservoir if needed
3	Booster	Replace existing booster pump at Glen Reservoir with a higher capacity unit
1	Other (Emergency Preparedness)	Purchase 250 kw trailer-mounted generator for Wilcox and K-3
2	Other (Preventative Maintenance)	Upgrade SCADA hardware, software and communications radios to prevent obsolescence
3	Other (Preventative Maintenance)	Replace Uniclor with Chlortec chlorine generators to prevent obsolescence

KINNELOA IRRIGATION DISTRICT
WATER MASTER PLAN

10.0 COST ESTIMATES FOR REQUIRED IMPROVEMENTS

10.1 *Pipelines*

Cost estimates for pipeline replacements as described in Section 7.1, are taken from a study prepared by ASL Consulting Engineers for the KID in April 1996. Cost estimates were updated in July 2002 and adjusted for inflation and current construction costs in by the General Manager in 2018. Most of the replacement pipelines are needed to meet 1,250 gpm fire flow and 450 feet vehicular distance requirements. Category definitions are as follows: EP-Emergency Preparedness; PM-Preventive Maintenance; OPS- Operational Improvement. The estimated costs are shown in Table 10.1. The smaller projects should be bundled in dollar amounts not less than \$150,000 for the district to get the best prices on these projects

TABLE 10.1
PIPING IMPROVEMENTS COST ESTIMATES

Priority	Main Size	Description		Category	Cost
		From	To		
1	8"	Sierra Madre Villa at Windover Rd.	Corner of 2090 and 2060 Villa Heights Road	EP 1840 ft.	\$200,000
2	8"	Fairpoint Street and Sierra Madre Villa	Sierra Madre Villa and Barhite Street	OPS/PM 450 ft.	\$50,000
3	4"	Eastern portion of Fairpoint St.	Last service on Fairpoint St.	EP/PM 950 ft.	\$100,000
4	8"	Country Lane	Southeast Corner of 1747 Country Lane	EP 270 ft.	\$30,000
5	8"	Kinclair Dr.	Rear of 2150 Kinclair Dr.	EP 250 ft.	\$40,000
6	8"	Kinclair Dr.	#4 Cricklewood Path	EP 400 ft.	\$60,000
7	8"	Kinneloa Canyon Rd.	Rear of 2044 Piccadilly Ln.	EP 250 ft.	\$40,000
8	8"	Intersection of Vosburg St. & Lower Pasadena Glen Rd.	Front of 1658 Pasadena Glen Rd.	EP/PM 350 ft.	\$50,000
9	8"	Edgecliff Lane from Villa Knolls	End of Cul-de-sac	EP/PM 700 ft.	\$90,000
10	8"	Larmona Drive & Kinneloa Mesa Road	1908 N. Kinneloa Canyon Rd. (Doyne Rd. Project)	EP 2000 ft.	\$575,000
11	8"	Villa Knolls Drive	End of Harwood Point	EP/PM 1960 ft.	\$300,000
12	8"	Sierra Madre Villa	3336 Villa Mesa	EP/PM 300 ft.	\$50,000

Priority	Main Size	Description		Category	Cost
		From	To		
13	12"	Glen Reservoir	Intersection Villa Highlands & Sierra Madre Villa Includes Slope from Pasadena Glen to Barhite	EP/OPS 3100 ft.	\$600,000
14	10"	Wilcox Well	Wilcox Reservoir Line	EP/OPS/PM 500 ft.	\$70,000
SUBTOTAL					\$2,250,000
Engineering, Design, and Planning					\$500,000
Construction Management and Inspection					\$200,000
SUBTOTAL					\$700,000
TOTAL PIPELINE PROJECTS					\$2,955,000

10.2 *Booster Pump Station Improvements*

Cost estimates for installation of some of the booster pump improvements at the Wilcox Reservoir that were required for the Doyme Road Development (Tract 44323) were developed in a report prepared by ASL Consulting Engineers for the KID and dated June 3, 1996. Cost estimates were up-dated in February 2002 but were not included in the KID capital project budget because it was expected that these improvements would be constructed at the developer's expense. However, since the development as originally planned has been abandoned by a new owner of the property, the cost of an additional booster at the Wilcox Reservoir is not included.

Cost estimates for installation of other booster pump improvements were developed in a report prepared by ASL Consulting Engineers for the KID and dated November 3, 1995. Cost estimates were up-dated in February 2002 and have been adjusted by the General Manager in 2018 for current construction costs and inflation.

Costs for improvements to the booster pumps at the Wilcox Reservoir and Glen Reservoir are included in the KID capital project budget. Costs include engineering, inspection, management and contingency

Booster Pump Station Improvements are shown in Table 10.2.

TABLE 10.2
BOOSTER PUMP STATION IMPROVEMENTS

Priority	Description	Estimated Costs
1	Replace the existing 50 HP oil lubricated booster pump at Wilcox Reservoir with a water-lubricated pump.	\$30,000
2	Construct improvements to the Booster Pump at Glen Reservoir	\$60,000
	Total Pump Station Improvements	\$90,000

10.3 *Tunnel Improvements*

The pipeline from the upper Low-Pressure Tunnel face to the new High/Low combiner was replaced in 2006. The existing High-Pressure pipeline was not replaced but the line was suspended from a new cable to the combiner to protect it from landsides. The lower Low-Pressure Tunnel pipeline was not replaced since there was no water exiting that tunnel at the time of the construction work in 2006. The combined High/Low Pressure pipeline from the combiner to the Kinneloa Canyon West Debris Basin may also need to be replaced in future years. The cost estimates for the remaining pipelines are shown in Table 10.3.

TABLE 10.3
TUNNEL IMPROVEMENTS

Priority	Description	Cost Estimate
1	Replace the combined High/Low Pressure Tunnel Pipeline from combiner to Kinneloa Canyon West Debris Basin	\$200,000
2	Replace the lower Low-Pressure Tunnel Pipeline	\$ 61,000
3	Replace other tunnel pipelines as required	\$100,000
	Total Tunnel Improvements	\$361,000

10.4 *Costs of Other Improvements*

Cost estimates for the construction or purchase of other improvements are based upon estimates by the General Manager and are shown in Table 10.4.

TABLE 10.4
OTHER IMPROVEMENTS

Priority	Description	Estimated Cost
1	Purchase 250 kw portable generator for Wilcox and K-3	\$50,000
2	Upgrade SCADA hardware, software and communications radios to prevent obsolescence	\$70,000
3	Replace Uniclор with Chlortec chlorine generators	\$20,000
	Total Other Improvements	\$140,000

10.5 *Total Costs*

Table 10.5 shows total estimated costs for all necessary improvements as identified in this master plan. Cost estimates include design, inspection, construction management and contingency costs. Improvements identified to be installed and financed by developers are not included. Costs for the items identified as other work were developed for this master plan from cost estimates by the General Manager.

TABLE 10.5
TOTAL ESTIMATED COSTS

No.	Description	Cost Estimate
1	Pipeline Improvements	\$2,955,000
2	Pump Station Improvements	\$90,000
3	Tunnels	\$361,000
4	Other Improvements	\$140,000
5	Planned Maintenance (from Section 8)	\$397,000
	TOTAL Estimated Costs	\$3,943,000

APPENDIX

EXHIBIT I
RESERVOIR IMPROVEMENTS

RESERVOIR IMPROVEMENTS (Revised in 2018 by the General Manager)

Cost estimates for District funded improvements to reservoirs are not included in the Water Master Plan. Since these costs were estimated in 1996, these projects will need to be re-evaluated if they are pursued in the future.

Existing Reservoirs

In April 1996, ASL Consulting Engineers conducted a study for the KID to identify reservoir improvements, which would have to be made to comply with the KID Fire Preparedness Policy. The results of that study indicate that additional capacity is required at the Holly Tanks, Glen Reservoir and East Tank. However, the completion of the East Tank – West Tank Connector Pipeline project added the West Tank capacity of 500,000 gallons provided a combined east/west pressure zone capacity of 650,000 gallons. Table I has been revised to reflect the combined pressure zone. In addition, since it is unlikely that the East Tank can be replaced due to access problems, it has been deleted from Table II because it would be more feasible to add storage to West Tank. Most reservoir improvements would require an extensive environmental review process.

Table I compares the required future reservoir storage capacity with the existing reservoir capacity for each service zone. Wilcox Reservoir with a capacity of 1,125,000 gallons is a forebay for the Wilcox Well and is not included. Required capacity is the sum of maximum day demand, operational capacity, and fire flow.

**TABLE I (Revised 2018)
REQUIRED RESERVOIR CAPACITY**

Reservoir	Maximum Day Demand (Gal.) *	Operational Capacity (Gal.) *****	Fire Flow (Gal.) **	Required Capacity (Gal.)	Existing Capacity (Gal.)	Additional Capacity Required (Gal.)
Eucalyptus Reservoir	308,160	77,000	300,000	685,160	180,000	505,160
Holly/Sage Tanks	702,720	176,000	300,000	1,178,720	525,000	653,720
East/West Tanks****	365,760	58,000	300,000	723,760	650,000	73,760
Brown/Glen Reservoir	298,080	75,000	300,000	670,080	250,000	420,080
Vosburg Reservoir	643,680	161,000	300,000	1,104,680	1,250,000	0

* Maximum Day Demand = 60 min. x 24 hours x max day demand (gpm/service).

** Fire Flow = 1,250 gpm for 4 hours.

*** Operational storage not required.

**** West Tank Maximum Day Demand based on (gpm/acre). East and West service zones were combined in 2017.

***** 25% of maximum day demand.

The proposed reservoir improvements are shown in Table II.

TABLE II (Revised 2018)
PROPOSED RESERVOIR IMPROVEMENTS

Tank	Description
Holly Tanks	Remove both existing reservoir in two stages. Construct new concrete reservoir in two stages and miscellaneous site improvements. Increase existing Holly Tanks to provide total 1-MG storage.
Glen Reservoir*	Demolish existing 0.15 MG reservoir. Construct new 0.5 MG concrete reservoir and miscellaneous site improvements.
Eucalyptus Reservoir	Emergency connections, generators and tunnel supply are considered to make up storage deficit.

* Low priority because Glen Reservoir has back up storage in Vosburg Reservoir.

Cost estimates for District funded improvements to reservoirs were developed in a study by ASL Consulting Engineers for the KID and dated April 1996. The Estimated cost for improvements to Holly Tanks and Glen Reservoir are shown in Tables III, and IV respectively. Cost estimates for East Tank improvements were deleted in this 2018 revision. All costs are in 1996 dollars.

TOTAL ESTIMATED COSTS

No.	Description	Cost Estimate
1	Holly Reservoir Improvements	\$612,000
3	Glen Reservoir Improvements	\$624,500
	Total Reservoir Improvements	\$1,236,500

**TABLE III
HOLLY RESERVOIR IMPROVEMENTS COST ESTIMATE**

Item	Quantity	Unit	Description	Unit Price	Total Price
PHASE I					
1	1	L.S.	Mobilization/Demobilization	\$6,750.00	\$6,750.00
2	1	L.S.	Modify Existing Inlet/Outlet and Tunnel Well Piping	\$5,000.00	\$5,000.00
3	1	L.S.	Demolish and Remove West Reservoir	\$25,000.00	\$25,000.00
4	275	L.F.	Install Excavation Shoring, Entire Site	\$30.00	\$8,250.00
5	900	C.Y.	Excavate Entire Site	\$30.00	\$27,000.00
6	1	L.S.	Install Sub drain System	\$4,000.00	\$4,000.00
7	1	L.S.	Install Inlet/Outlet Piping	\$3,000.00	\$3,000.00
8	1	L.S.	Construct West Half of New Reservoir	\$200,000.00	\$200,000.00
9	1	L.S.	Test, Disinfect, and Place West Half of Reservoir in Service	\$2,000.00	\$2,000.00
PHASE II					
1	1	L.S.	Demolish and Remove East Reservoir	\$25,000.00	\$25,000.00
2	1	L.S.	Install Sub drain System	\$4,000.00	\$4,000.00
3	1	L.S.	Install Inlet/Outlet Piping	\$5,000.00	\$5,000.00
4	1	L.S.	Construct East Half of New Reservoir	\$200,000.00	\$200,000.00
5	1	L.S.	Test, Disinfect, and Place East Half of Reservoir in Service	\$2,000.00	\$2,000.00
6	200	C.Y.	Backfill and Remove Shoring	\$50.00	\$10,000.00
7	1	L.S.	Construct Site Improvements, A.C. Pavement, Landscaping and Irrigation, and Site Drainage Facilities	\$15,000.00	\$15,000.00
SUBTOTAL					\$542,000.00
Engineering Design and Planning					\$30,000.00
Soils Investigation					\$10,000.00
Environmental Documents					\$10,000.00
Construction Administration and Inspection					\$20,000.00
SUBTOTAL					\$70,000.00
TOTAL PROJECT					\$612,000.00

**TABLE IV
GLEN RESERVOIR IMPROVEMENTS COST ESTIMATE**

Item	Quantity	Unit	Description	Unit Price	Total Price
1	1	L.S.	Mobilization/Demobilization	\$6,000.00	\$6,000.00
2	1	L.S.	Temporary Relocation of Long Tunnel Pipeline	\$2,000.00	\$2,000.00
3	1	L.S.	Salvage Pump, Electrical, and Chlorination Equipment	\$6,000.00	\$6,000.00
4	1	L.S.	Demolish A.C. Pavement	\$2,000.00	\$2,000.00
5	1	L.S.	Demolish and Remove Existing Reservoir Structure and Appurtenances	\$35,000.00	\$35,000.00
6	300	L.F.	Install Excavation Shoring	\$30.00	\$9,000.00
7	1,900	C.Y.	Excavate Reservoir Pad	\$35.00	\$66,500.00
8	1	L.S.	Install Sub drain System	\$8,000.00	\$8,000.00
9	1	L.S.	Install Reservoir Inlet/Outlet and Drain Piping	\$5,000.00	\$5,000.00
10	1	L.S.	Construct Reservoir	\$350,000.00	\$350,000.00
11	1	L.S.	Test, Disinfect, and Place Reservoir in Service	\$3,000.00	\$3,000.00
12	1	L.S.	Backfill and Grade Site	\$7,000.00	\$7,000.00
13	1	L.S.	Install Chlorination, Pump, and Electrical Equipment	\$15,000.00	\$15,000.00
14	1	L.S.	Construct Site Improvements, A.C. Pavement, Landscaping, and Irrigation	\$10,000.00	\$10,000.00
SUBTOTAL					\$524,500.00
Engineering Design and Planning					\$45,000.00
Soils Investigation					\$10,000.00
Environmental Documents					\$15,000.00
Construction Management and Inspection					\$30,000.00
SUBTOTAL					\$100,000.00
TOTAL PROJECT					\$624,500.00

EXHIBIT II
SCHEMATIC OF WATER SYSTEM

KINNELOA IRRIGATION DISTRICT HYDRAULIC SCHEMATIC

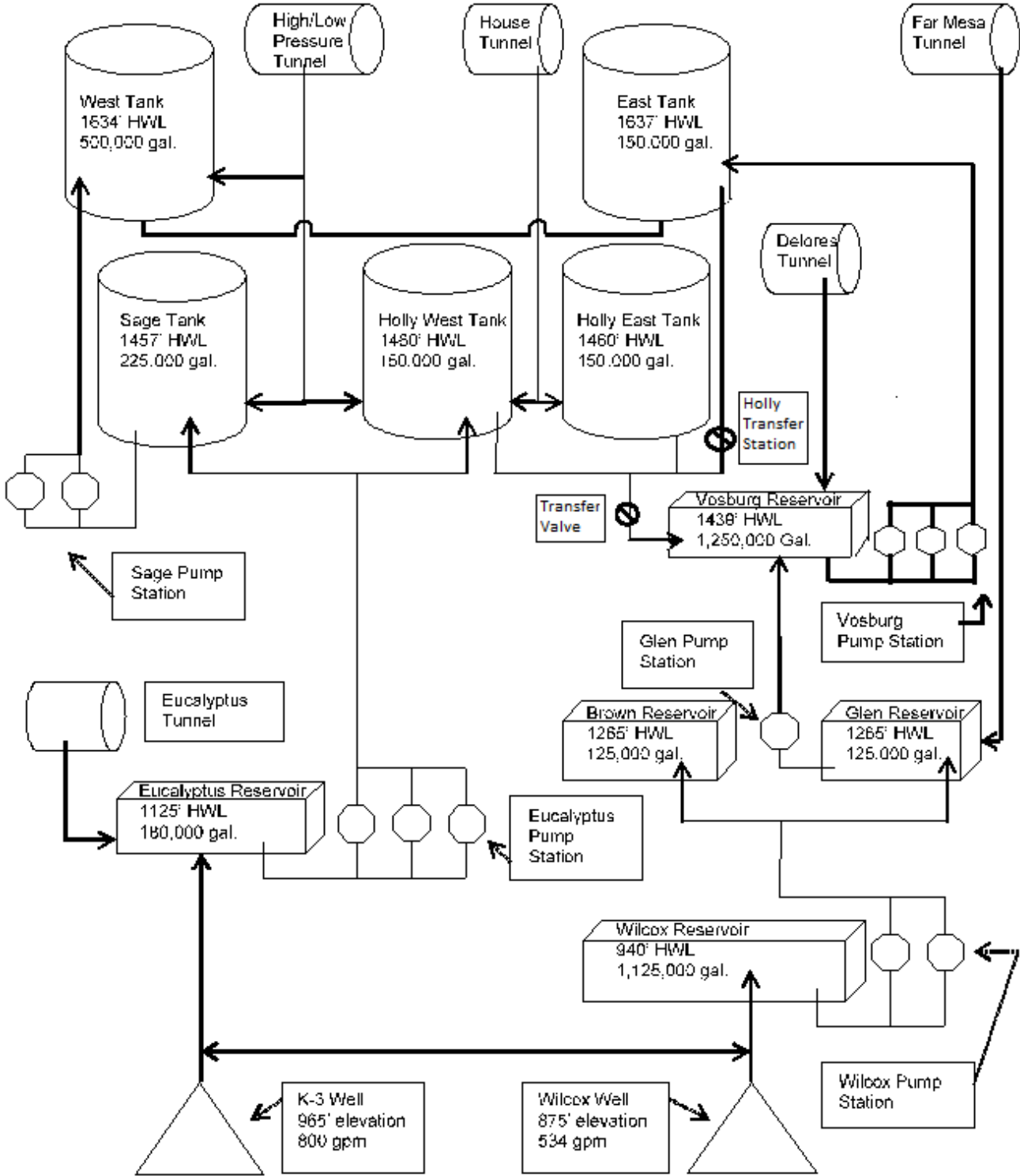

EXHIBIT III
FIRE PREPAREDNESS POLICY

FIRE PREPAREDNESS POLICY
FOR
THE KINNELOA IRRIGATION DISTRICT

Prepared for

The Kinneloa Irrigation District
1999 Kinclair Drive
Pasadena, CA 91107
(626) 797-6295

Prepared by:

ASL Consulting Engineers
3280 East Foothill Boulevard
Suite 350
Pasadena, CA 91107

February 1997

Revised by:

Melvin L. Matthews
General Manager

June 2018

KINNELOA IRRIGATION DISTRICT

FIRE PREPAREDNESS POLICY

INTRODUCTION

The Kinneloa Irrigation District (KID) provides water service to approximately 500 acres of hillside customers in northeast Pasadena. The Angeles National Forest borders the District on the north. Under certain weather conditions, wild fire danger is extremely high. Santa Ana winds have the capability to drive wild fires into the District with potential to cause major damage. The 1993 Altadena wild fire was the latest example of the potential fire danger. There are many factors that contributed to the Altadena wildfire damage. These factors are as follows:

- The availability of water for fire protection.
- Fuel source availability.
- Coordination of manpower.
- Equipment deployment.
- Limited ingress and egress.
- Fire preparedness.

Complete protection from major natural disasters such as wild fires is extremely difficult to provide. Preparation for all possible contingencies is impossible. The KID has determined that there are some water issues that exceed standard fire protection measures that may reduce wild fire damage to the community. These measures as applicable to the KID are identified in the KID Fire Preparedness Policy (FPP). The FPP issues identified are not necessarily immediately achievable. The FPP measures identified are a goal to be achieved to minimize future wild fire damage to the KID community.

The existing District facilities provide the level of structure fire protection originally intended. Recent wild fire events have identified several areas where water system performance above original design standards and, in some cases, additional capacities above current standards would be prudent. The FPP is an attempt to identify these areas and set goals to achieve reasonable standards.

The FPP identifies goals in four areas. These areas are as follows:

- Reservoir storage to maintain gravity supply to the distribution system for each pressure zone.
- Distribution piping to deliver the water supply to all areas of the District.
- Pumping capacity to supplement reservoir storage and transfer water to higher zones when necessary.
- Operational guidelines necessary to maximize system performance and minimize water loss during a wild fire event.

Following is a detailed discussion of each goal:

1. Reservoir Storage

The FPP reservoir storage goal is to provide storage in each zone to supply fire flow to multiple fire hydrants simultaneously in addition to customer demand. Fire flow storage goal is to provide 1,250 gpm at two locations for duration of two hours (300,000 gallons) plus 20 gpm for each customer

for two hours (2,400 gallons per customer). The following table identifies the reservoir fire flow storage goals for each zone. Total services include planned developments.

Service Zone	Total Services	Customer Demand (gallons)	Fire Storage (gallons)	FPP Goal (gallons)	Existing Storage (gallons)
Eucalyptus Zone	62	148,800	300,000	448,800	180,000
Holly/Sage Zone	205	492,600	300,000	792,600	525,000
East/West Tank Zone	86	206,800	300,000	506,800	650,000
Brown/Glen Zone	77	184,800	300,000	484,800	250,000
Vosburg Zone	195	468,000	300,000	768,000	1,250,000

Note: FPP storage goal does not include reservoir operational storage. The FPP reservoir storage goal will be accomplished through new reservoir construction resulting from development and/or replacement or reconstruction of existing reservoir facilities.

2. Distribution Piping

The FPP distribution piping goal is to improve the distribution piping network to increase the delivery capability to all fire hydrants and customer services. The original system design required capability of delivering 750 gallons per minute of water to a single fire hydrant. Most of the current distribution piping is believed by management and the District's engineer to have the capability to meet this requirement through hydraulic modelling and actual testing. However, flow requirements have been increased by revisions to the Los Angeles County Fire Department regulations. New construction within the District requires a minimum of 1,250 gpm flow for 2-hour duration.

The FPP goal is to improve the distribution system piping within each service zone to provide 1,250 gpm flows to two fire hydrants flowing simultaneously, plus a flow of 20 gpm for each customer service within the service zone. **This goal is not immediately achievable.** The goal will be accomplished by adequately sizing new water mains and replacing existing mains as required due to system modifications and pipe deterioration due to age. Additional fire hydrants will be added where required to meet the revised Los Angeles County requirement of 450 feet maximum vehicular distance to structures.

3. Pumping Capacity

The FPP pumping capacity goal is to improve the reliability, efficiency, and capacity of the District's pumping facilities. The existing pumping facilities have adequate capacity to provide maximum day domestic demands. Tunnel well water is required to meet maximum day domestic demand for some zones. Development of additional customer services will increase demand above current pumping capacities. Additional pumping capacity is required to meet the additional demands.

The FPP pumping capacity goal is to improve pumping facilities to the following standards:

- A. Pumping capacity for each zone will be sufficient to pump maximum day demand during Edison Company off-peak demand 16-hour daily pumping period.

- B. Pumping capacity will be sufficient to replace fire flow storage within a minimum of one 24-hour period.
- C. Pump facilities for each zone will include a minimum of two pumps:
 - One (1) Duty
 - One (1) Standby

There will be an alternative for larger capacity facilities having three pumps:

- Two (2) Duty
- One (1) Standby

Pumps will be high efficiency vertical turbine pumps, with pump can manifold, aboveground discharge, and pump control valve check valves to minimize system pressure surges. Each facility will include provisions for emergency generator lug connections. Emergency generator shall provide power to a minimum of one Duty pump. Pump station piping shall include provisions for bypass valve and bypass connections for fire engine pumping equipment or portable emergency pumping equipment.

The FPP goal will be accomplished by applying the above standards to all new pumping facility designs and upgrading existing facilities to above standards when capacity modifications are required or when pumping equipment is replaced.

4. System Operational Guidelines

The FPP guidelines were developed from discussions with KID staff focusing on the 1993 wild fire incident. The goal of the operational guidelines is to make efficient use of the water supply to protect the KID customers and maximize fire department suppression capabilities. In the event of wild fire danger, the KID staff will attempt to implement the following guidelines:

- A. General Manager or Senior Facilities Operator will coordinate water system operation with fire department deployment of manpower and equipment.
- B. Whenever possible, KID staff will attempt to minimize water waste by stopping visible leaks from damaged structures and/or irrigation systems. Water service to damaged structures and/or irrigation system may be turned off.
- C. Fire department pumping equipment may be deployed and connected to inter zone transfer facilities.
- D. Bypass valves or pumping facilities may be operated as required to make up reservoir storage losses and maintain adequate storage levels. Transfers between zones will be made only when necessary and only when transfer will not deplete zone storage below levels required to provide adequate fire protection. Transfer of water between zones will be at the discretion of the General Manager or Senior Facilities Operator.
- E. District emergency portable generators will be maintained and tested monthly and placed in service when required to provide emergency power for pumping to maintain adequate storage levels when anticipated power failure is expected for a duration of more than 2 hours.

Additional emergency generators will be provided at the discretion of the General Manager or Senior Facilities Operator.